



60Hz

Serving a wide range of slurry transport applications, STORMY-P series pumps are designed for long wear life, low energy consumption, excellent performance, and easy maintenance. With patented ACrS Tech and rugged construction, these abrasion and corrosion resistant slurry pumps provide economical solutions for challenging slurry transportation.

Slurry and Sand Pump

STORMY 6220P/8220P

Open Stand and Agitator Pump

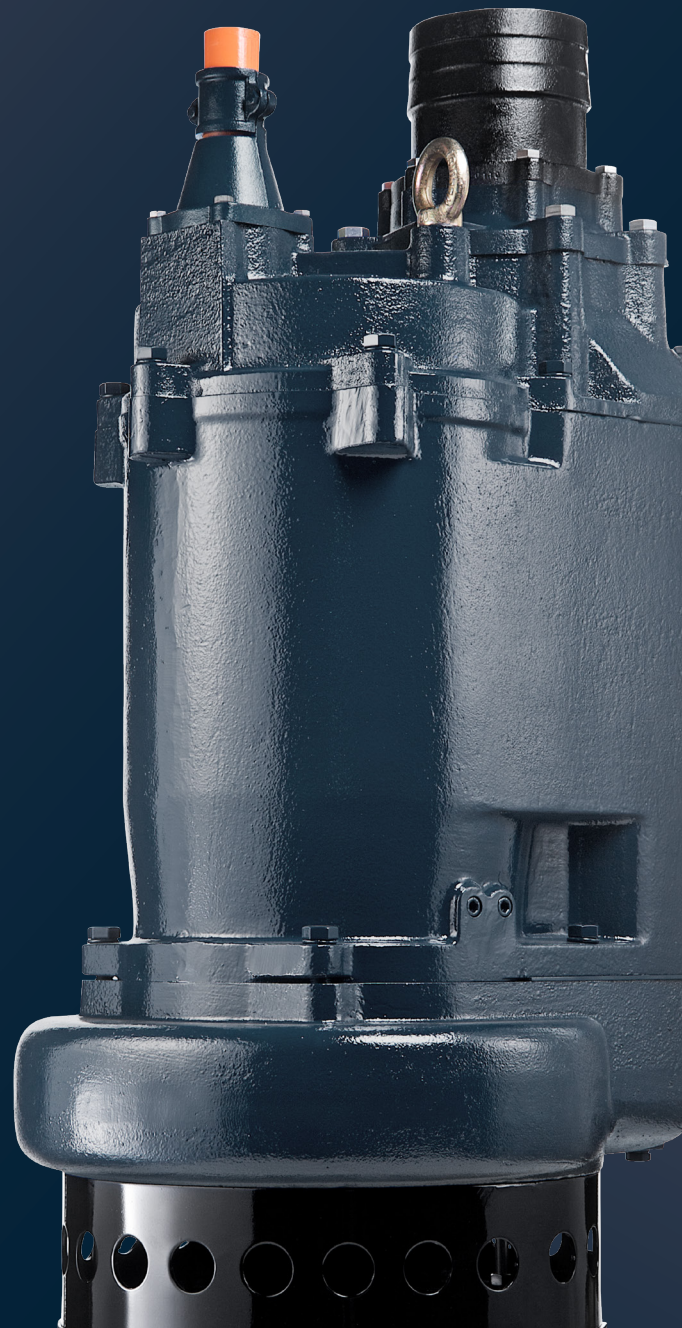

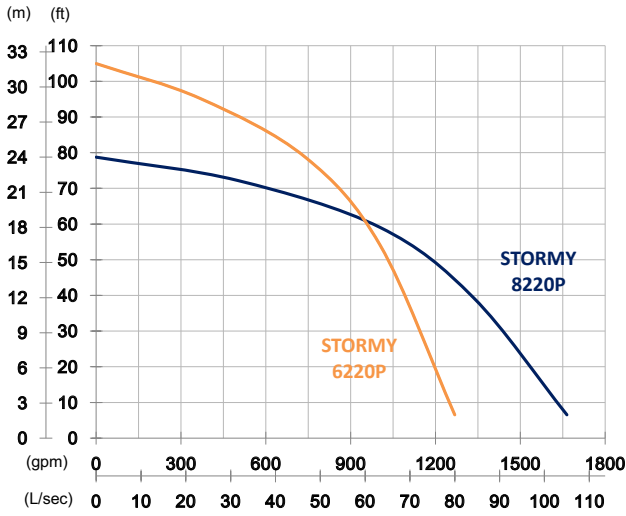

	STORMY 6220P	STORMY 8220P
OUTPUT	30 HP (22 kW)	30 HP (22 kW)
OUTLET	6" (150 mm)	8" (200 mm)
SOLID PASSAGE	1.4" (35 mm)	1.4" (35 mm)
Weight	761 lbs/345 kg	783 lbs/355 kg
HEAD	Rated: 79 ft, 24 m Max: 105 ft, 32 m	Rated: 59 ft, 18 m Max: 79 ft, 24 m
FLOW	Rated: 740 gpm, 46.7 L/s Max: 1268 gpm, 80 L/s	Rated: 1004 gpm, 63.3 L/s Max: 1664 gpm, 105 L/s

Pump Type	Electric Submersible Pumps	
Motor	Phase	3-Phase
	Type	Induction Motor
	Poles	4 Pole (1750 rpm)
	Insulation	Class F
	Protector	Circle Thermal Protector
	Starter	D.O.L.
Lubricant	Food Grade (ISO VG32)	
Specs.	Impeller Type	Opened
	Shaft Seal	Double Mechanical Seal
		Silicon Carbide VS Ceramic/Carbon
	Bearings	C3 Shielded ball bearings
Cable	CSA-Certified PVC Jacketed Cables	
	33 ft (10 m) or longer upon request	
Materials	Pump Casing	Ductile Iron
	Impeller	Chromium Iron
	Motor Frame	Gray Iron
	Motor Shaft	Stainless Steel
	Wear Plate	Chromium Iron
	Agitator	Chromium Iron
Max. Liquid Temperature	40°C (104°F)	
Max. Submersion Depth	20 m (66 ft)	
pH Range	pH 5 - pH 8	

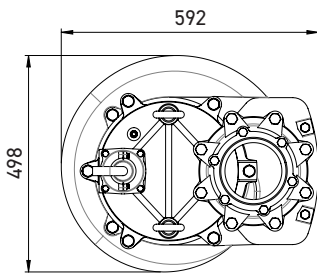

A

STORMY 6220P	1204
STORMY 8220P	1166

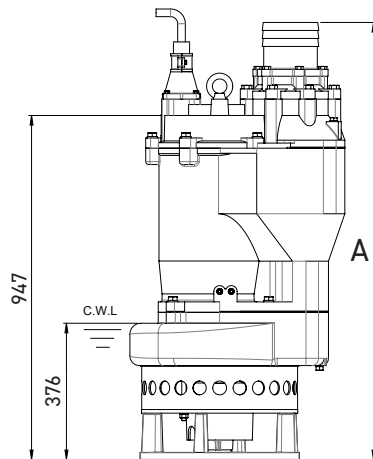

unit : mm

C.W.L. : Continuous running water level